

During the winter, attic insulation prevents heat within the house from escaping through the ceiling and into the unheated attic space. During the summer, it reduces outside heat from radiating downward through the attic and into the house. All insulating materials work on the principle of trapping. They have millions of tiny air pockets to restrict heat of trying to pass through.

The thermal resistance of insulation is expressed in R (RSI metric) values. In general, the thicker the insulation, the more air pockets it has and hence, has a higher capacity to resist heat transfer. Many older houses are probably under-insulated by today's standards and should be evaluated to determine if it is economically feasible to upgrade their insulation.

*Note that during a visual inspection, hidden problems may exist that are not documented due to limitations such as access, obstructions or stored goods.*

### **TYPES OF ATTIC VENTILATION:**

The maximum heat difference between the air in the attic and the outside air should be approximately 10° F (6° C) to avoid reducing the life of the roof covering. Never block off vents in winter, since moisture from the house will condense and cause problems. In a properly insulated attic, the ventilation will not lower the temperature in the house. The general rule of thumb is one square foot of free vent area for each 150 square feet (with no vapor barrier), or 300 square feet (with a vapor barrier) of attic floor.

**SOFFIT VENTS** – are provided on the underside of the eave either as grills or the preferred continuous type. Soffit vents are used in conjunction with roof, gable or ridge vents.

**ROOF VENTS** – are either round or rectangular and are cut in the roof near the top of the roof. The higher the better to allow hot air to rise and dissipate out through these vents.

**GABLE VENTS** – are louvered openings commonly used at the gable ends of gabled roofs.

**RIDGE VENTS** – are cut into the ridge of a roof and are popular with a cathedral ceiling.

**POWER VENTILATORS** and **GABLE VENTILATORS** – are equipped with a thermostat that turns on the unit when the attic temperature reaches a certain point and turns off when the attic cools.

### **TYPES OF ATTIC AND ROOF CONSTRUCTION:**

**Gable and Hip Roofs** – These are common and can be easily insulated by placing the insulation between the ceiling joists or bottom chords of trusses. A polyethylene vapor barrier must be placed under the insulation (warm side of insulation) to reduce any moisture entering the attic from the house. A provision should be made for unblocked adequate airflow from the eave of the roof (soffit vent) to the open attic portion of the structure. This is achieved by using air chutes or channels between insulation and the rafters or top chord on roof trusses.

**Cathedral Ceilings** – Due to the inherent lack of access, cathedral ceilings cannot be fully inspected for insulation or ventilation. It is very important that adequate ventilation be provided in these roof structures. The best ventilation system is one that uses continuous ridge and soffit vents to vent each rafter bay. When using cross purlins, there must be a minimum 1½" air space above the insulation and below the underside of the roof sheathing for adequate airflow (in some jurisdictions, the minimum air space requirement is 3"). This airflow is necessary to remove any condensation and reduce the build up of heat.

**One and One Half Story Houses** and **Mansard Roofs** – These types of attics have several small sections that must be properly insulated on the vertical knee walls, on the floor of the attic, on the sloping ceilings and on the top flat portion of the 1½ story area. The outer attic is treated as a non-heated area and it must be insulated and ventilated. Air can be allowed to enter through the soffit vents and exit up above the sloping ceiling to the attic space above the 1½ story portion. The top portion of the attic can be vented using roof or gable vents.

*Note: If using the older batt insulation with a paper backing (vapor barrier) make sure that the paper is on the warm side of the insulation or facing the finished wall or ceiling surface.*

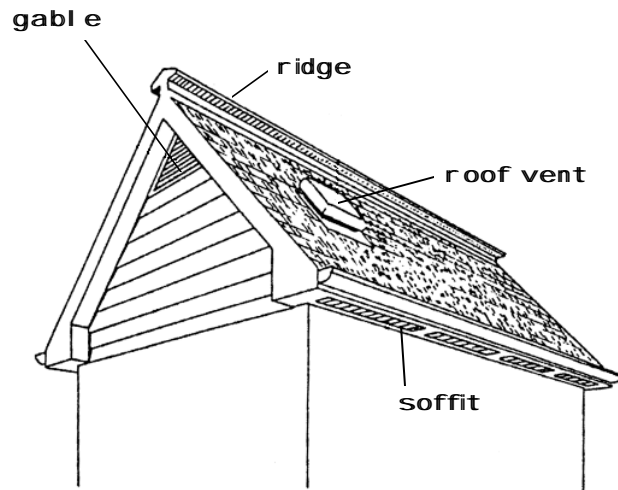

**DIFFERENT TYPES OF VENTILATION**

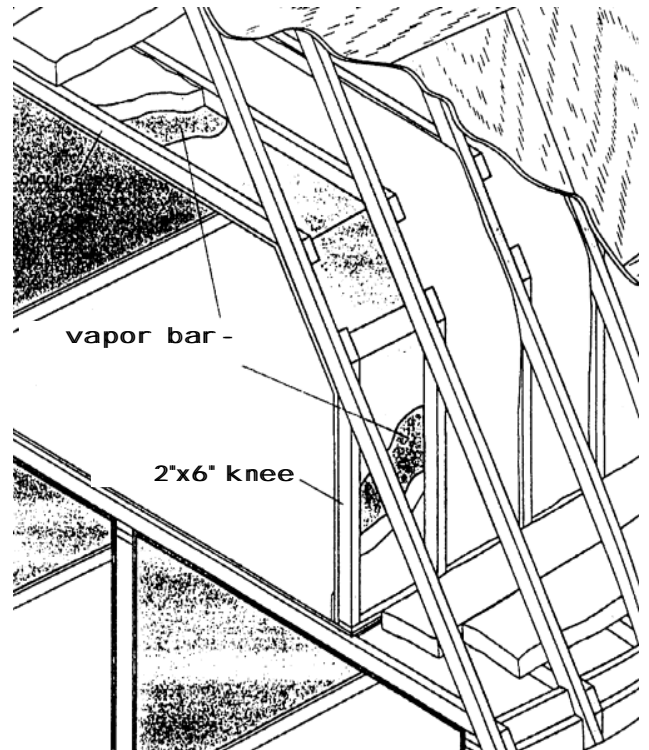

**TYPICAL INSTALLATION OF INSULATION IN A 1½ STORY ATTIC**

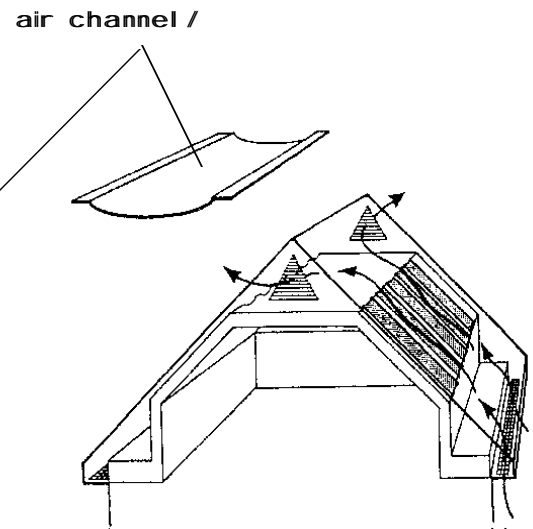
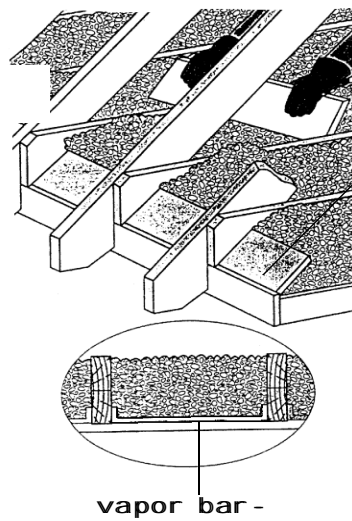
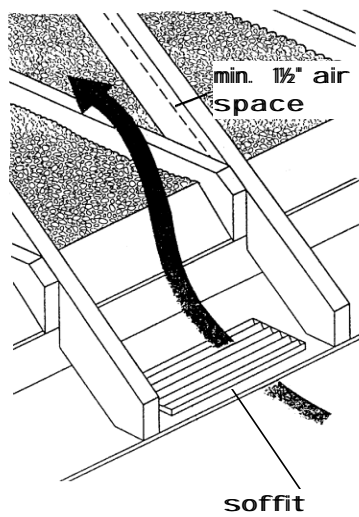

**AIR CHANNELS OR BAFFLES PROVIDE VENTILATION IN EACH RAFTER SECTION**